

# Wabo®WeatherSeam

Exterior Wall & Ceiling Seismic Expansion Control System

Features	Benefits
<ul style="list-style-type: none"> <li>• Weather resistant</li> </ul>	Continuous seal provides excellent water penetration resistance. Factory transitions available.
<ul style="list-style-type: none"> <li>• Aesthetically pleasing</li> </ul>	No visible aluminum hardware.
<ul style="list-style-type: none"> <li>• Versatility</li> </ul>	Used for interior and exterior conditions.
<ul style="list-style-type: none"> <li>• Flexibility</li> </ul>	Accommodates multi-directional seismic movement.
<ul style="list-style-type: none"> <li>• Colored seals</li> </ul>	Visual seals available in standard and custom colors.



## DESCRIPTION:

Wabo®WeatherSeam is a weather tight seismic expansion control system for interior and exterior walls and ceilings. An optional secondary moisture barrier is available for exterior applications. The colorable elastomeric seal completely covers the supporting aluminum frame creating a functional and attractive joint.

Wabo®WeatherSeam accommodates thermal movement and multidirectional seismic movement. Wider Wabo®WeatherSeam joints employ multiple seals with self-centering bars and a nylon reinforced pantograph mechanism. Seals are available in standard black, beige, gray or custom colors to match or compliment adjacent wall surfaces.

## RECOMMENDED FOR:

- Seismic expansion joint systems for projects in:
  - Health-care
  - Transportation
  - Recreation
  - Retail
  - Commercial
  - Educational
  - Other
- Exterior vertical expansion control systems in walls or ceilings.

## PACKAGING/COVERAGE:

- Aluminum profiles: standard 10 ft. lengths.
- Seals: longest practical continuous length.
- Accessories: packaged in manufacturers standard labeled carton



**TECHNICAL DATA:**

**Design Information:**

Wabo®WeatherSeam is available in three models; WSW, WSE and WSC. Model WSW utilizes a mechanical anchor to attach to the substrate. Model WSE utilizes an epoxy adhesive to attach to the substrate. Model WSC utilizes epoxy adhesive as well as mechanical anchors to attach to substrate.

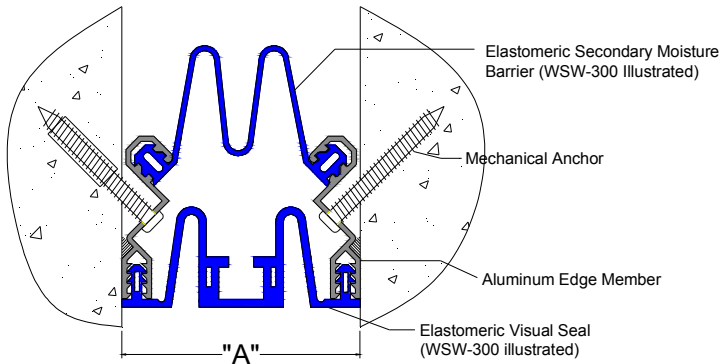

**Model WSW**

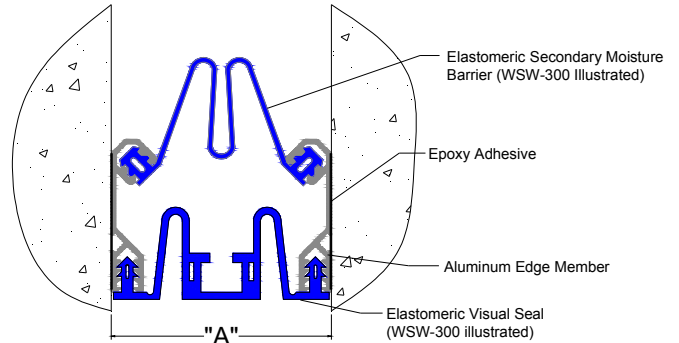

**Model WSE**

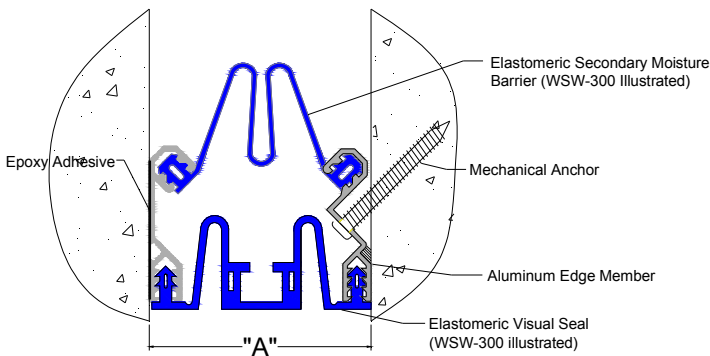

**Model WSC**

**Note: see product sales drawings for additional details**

**Additional Note: Models WSE and WSC are only for system sizes 200 thru 600.**

**Movement Table**

MODEL NUMBER WSW	NO. OF SEALS	JT OPENING "A"		TOTAL MOVEMENT	
		inches	mm	inches	mm
200	1	2.0	51	2.63	67
300	1	3.0	76	5.13	130
400	1	4.0	102	4.75	121
500	1	5.0	127	6.75	171
600	1	6.0	152	9.50	241
800	2	8.0	203	9.63	244
1000	2	10.0	254	13.63	346
1200	2	12.0	305	19.13	486
900	3	9.0	229	15.38	391
1500	3	15.0	381	20.25	514
1600	4	16.0	406	19.00	483
1800	3	18.0	457	28.50	724
2000	4	20.0	508	27.00	686
2400	4	24.0	610	38.00	965



## PHYSICAL PROPERTIES

**Aluminum Extrusions** – ASTM B221, alloy 6063-T5.

**Visual Seal** – Extruded profile. Material shall be Santoprene or manufacturers alternate material exhibiting a shore A hardness of 64 +/-5.

**Secondary Functional Seal** – Extruded profile. Material shall be a quality flame-retardant vinyl with a minimum material thickness of .063”.

**Self-Centering Bar and Pantograph Control Mechanism** – Material shall be manufactured incorporating corrosion resistant molded nylon components with spherical ends.

## APPLICATION:

### Installation Summary:

- Protect all expansion joint component parts from damage during installation and thereafter until completion of structure.
- Expansion joint systems shall be installed in strict accordance with the manufacturer's typical details and instructions along with the advice of their qualified representatives.
- Contractor shall provide proper and adequate adjacent construction to receive and support the seismic expansion control joint system. The supporting framework shall be of design to secure all threaded hardware and provide rigidity for the proper installation and function of the joint system.
- Floor, wall, and ceiling construction and materials shall be designed to allow for proper installation of system and its components. Construct wall recess in accordance with manufacturer's requirements.

### For Best Results:

- Install when concrete substrate is clean, sound, dry, and cured (14 day minimum). Follow International Concrete Repair Institute (ICRI) concrete repair and maintenance guidelines.
- Do not install if the joint's anticipated movement will exceed the system's movement range.
- Protect the work area with appropriate plastic sheeting.
- Minimize splice points by installing seals in longest possible continuous lengths.
- Do not allow any of the components to freeze prior to installation. Store all components out of direct sunlight in a clean, dry location between 50°F (10°C) and 90°F (32°C). Store all material off of the ground.
- Shelf life of chemical components is approximately 1 years.
- Periodically inspect the applied material and repair localized areas as needed. Consult a Watson Bowman Acme representative for additional information.
- Make certain the most current version of the product data sheet is being used. Please consult the website ([www.wbacorp.com](http://www.wbacorp.com)) or contact a customer service representative.
- Proper application is the responsibility of the user. Field visits by Watson Bowman Acme personnel are for the purpose of making technical recommendations only and not for supervising or providing quality control on the jobsite.

### Related Documents:

- Material Safety Data Sheets
- Wabo®WeatherSeam Specification
- Wabo®WeatherSeam Sales Drawings
- Wabo®WeatherSeam Installation Procedure



**LIMITED WARRANTY:**

Watson Bowman Acme Corp. warrants that this product conforms to its current applicable specifications. WATSON BOWMAN ACME CORP. MAKES NO OTHER WARRANTY, EXPRESS OR IMPLIED, INCLUDING ANY WARRANTY OF MERCHANTABILITY OR WARRANTY OF FITNESS FOR A PARTICULAR PURPOSE. The sole and exclusive remedy of Purchaser for any claim concerning this product, including, but not limited to, claims alleging breach of warranty, negligence, strict liability or otherwise, is the replacement of product or refund of the purchase price, at the sole option of Watson Bowman Acme Corp. Any claims concerning this product shall be submitted in writing within one year of the delivery date of this product to Purchaser and any claims not presented within that period are waived by Purchaser. IN NO EVENT SHALL WATSON BOWMAN ACME CORP. BE LIABLE FOR ANY SPECIAL, INCIDENTAL, CONSEQUENTIAL (INCLUDES LOSS OF PROFITS) OR PUNITIVE DAMAGES. Other warranties may be available when the product is installed by a factory trained installer. Contact your local Watson Bowman Acme representative for details. The data expressed herein is true and accurate to the best of our knowledge at the time published; it is, however, subject to change without notice.

**Contact**

*Watson Bowman Acme Corp. 95 Pineview Drive, Amherst, NY 14228  
phone: 716-691-7566 / fax: 716-691-9239 / web site: <http://www.wbacorp.com>*

**WaboWeatherSeam\_1008**